

Introduction to Housing

by Claudio Acely Jr.

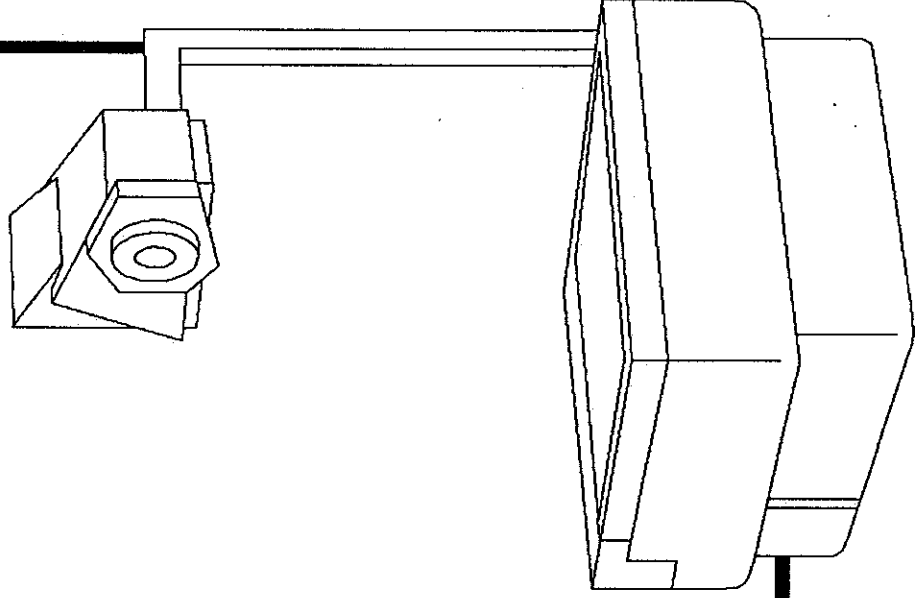

INTRODUCTION TO HOUSING

1. **Different views and perceptions & the concept of housing**
From artifact to economic asset
2. **The multidisciplinary character of housing**
Different fields of study and activities
3. **The complexity of housing**
Political, technological and economic facets
4. **Convergent and Divergent interests in the housing sector**
Various actors involved in housing production and consumption
5. **From housing to shelter**
A multi-sectoral profile: land, infrastructure & location (site)
6. **The importance of housing: a historical background**
First appearance of housing as an important point in government intervention
The industrial revolution in Western Europe
The CIAM city and housing
Concepts and ideas exported to developing countries
Brasilia, Chandigarh, Abuja, Dodoma, Gaborone, etc.
7. **Housing and development policies**
The United Nations development decade
Housing & development models: Modernization and Industrialization
Basic Needs & Redistribution with Growth
The UN Habitat Conference in Vancouver (1976)
From conventional housing to slum/squatter upgrading and sites & services
The international agendas & the role of bilateral and multilateral development agencies
SAP-Structural Adjustment Programmes
8. **The World Bank**
Concepts and ideas exported to developing countries
9. **Some preliminary evaluation and general trends**
Effects on the housing sector
Replicability
From project lending to policy lending
10. **Trends and question marks**
Are we going in the right direction ?
11. **From "housing as a product" to "housing without houses"**
New roles assigned to governments and policy innovation (or degeneration ?)
12. **GSS-Global Strategy for Shelter to the Year 2000**
Enabling Strategies
13. **The World Bank-UNCHS Housing Indicator Program**
Recent attempts to understand and monitor the performance of the housing sector
Housing Demand & Housing Supply
Consumers, producers, finance institutions, local & central governments
Comparative basis for policy formulation

1. THE CONCEPT OF HOUSING

It is a broad and complex issue. There are different views and interpretations depending on the professional, ideological and political background of the one who is studying it.

In urban development processes we can identify a number of actors whose interests are convergent and sometimes totally divergent. Public sector agencies are known to have peculiar approaches to housing problems which are contradictory to one another although they belong to the same governmental structure and should, in principle, follow the same policy and guidelines. They often have their agenda and their hidden agenda while negotiating or exposing their views to other actors.

Even within a particular neighbourhood or community, it is also possible to identify different interests among groups of residents, individuals and community organizations. It is likely that political, economic and even religious differences influence their perceptions and views about the housing problems and the best approaches to solve them.

The same phenomenon is verified when we look at the way the various professional categories operate in the process of policy making, planning, design and management of urban development programmes. Very often, their attitudes are so much identified with the ones of the organizations they belong to that it is possible to make parallels.

It is very dangerous to make stereotypes but let's assume that some of these professionals have a peculiar way of looking and understanding what housing is all about. It is not a black box since there are variations according to the degree of engagement and commitment of each professional in efforts to solve the crux of the problem.

ENGINEER

Looks at the building and production process, with certain emphasis to quality and stability control. He has a strong technological discourse. Housing is an artifact composed of five elements that form an enclosure covered by a roof. It is a standard shelter where people live and feel safe.

The inhabitant is treated as a user.

ARCHITECT

Looks at housing as the product of a spatial residential planning and maybe as a process whenever the user's involvement is considered. It is the spatial condition through which human beings will realize and fulfil their biological, spiritual and material needs.

The inhabitant is probably a resident, a user and maybe a partner in the spatial planning.

ECONOMIST

Looks at housing as an economic asset or just a sector within a macro development process. It is a capital good to be produced and consumed, it has implicit and explicit costs and can generate both the financial resources and employment. Housing is related to productivity. The inhabitant is a consumer, a beneficiary or a client.

SOCIAL WORKER

Might look at housing as a pre-condition for human development. Housing has a catalytic role because it aggregates the community to work together for accomplishing better living conditions. Housing has the potential to create conditions for social changes, specially when the inhabitants are involved in the process. The inhabitant is a human being who is struggling for his basic needs.

PLANNER

Looks at housing as a component in a development strategy with a strong policy perspective for launching and guiding urban development processes. His view is broad and multidisciplinary. The inhabitant is part of the group of beneficiaries of public policies. His target is the whole population, stratified in classes or social-economic groups.

**LEGAL ADVISER or
MUNICIPAL OFFICER**

Looks at housing as an important asset in revenue generation through efficient property tax and land ownership registration system. The inhabitant is just a tax payer, he is a citizen who contributes to municipal development.

POLITICIAN

Housing is an important affair of the state that should be extended to the whole population. It is a visible, tangible artifact and must be within reach of the majority of the population, specially if elections are bound to take place. The inhabitant is seen as part of the population and beneficiary of public intervention. A potential voter.

THE INHABITANT

Housing has different dimensions. It basically involves the house as a building artifact, a plot and the provision of basic infrastructure such as water, electricity and sewerage. Accesses and roads and community services and building materials loans might be included as part of housing. There is a variety of perceptions which depends on the type of settlements (legal and illegal), the living conditions, the location within the urban fabric of the city and obviously the individual ability of the

HOUSING HAS A MULTIDISCIPLINARY SCOPE

HOUSING PRODUCTION
HOUSING DESIGN
HOUSING ECONOMICS
HOUSING POLICY
HOUSING NEEDS
HOUSING DEFICIT
HOUSING RIGHTS
HOUSING SUPPLY
HOUSING SECTOR
HOUSING FUND

HOUSING TECHNOLOGY
HOUSING FINANCE
HOUSING DELIVERY SYSTEMS
HOUSING EXPENDITURES
HOUSING TAXATION
HOUSING SHORTAGE
HOUSING SUPPLY
HOUSING DEMAND
SELF-HELP HOUSING
HOUSING PROGRAMME
CONVENTIONAL HOUSING
LOW INCOME HOUSING

inhabitant to capture this various dimensions.

These different views and perceptions leads us to the conclusion that housing has a multidisciplinary scope which forces us to search for a broader definition of the term than can establish an integrated view.

HOUSING PRODUCTION
HOUSING TECHNOLOGY
HOUSING DESIGN
HOUSING FINANCE
HOUSING ECONOMICS
HOUSING DELIVERY SYSTEMS
HOUSING POLICY
HOUSING EXPENDITURES
HOUSING TAXATION
HOUSING NEEDS
HOUSING DEFICIT
HOUSING RIGHTS
HOUSING SUPPLY
HOUSING DEMAND
HOUSING SECTOR
SELF-HELP HOUSING
CONVENTIONAL HOUSING
HOUSING FUND
HOUSING PROGRAMMES
LOW INCOME HOUSING

Housing involves the problem of LAND which by itself involves the complexity of its location, its value, its accessibility, legal status.

Housing involves obvious linkages with INFRASTRUCTURE development like water supply, drainage, sewerage, electricity, roads and even community services like schools, health centres, transportation. This means that housing has a multi-sectoral profile.

Housing involves LOCATION and its relationship to employment opportunities, commercial opportunities and income generation.

Housing involves social welfare and uprise in the social economic pyramid of a society.

Housing has a multi-sectoral profile.

H O U S I N G	LAND	LOCATION VALUE ACCESSIBILITY LEGAL STATUS
	INFRASTRUCTURE	WATER, ELECTRICITY, SEWERAGE, DRAINAGE, ROADS, COMMUNITY SERVICES, TRANSPORTATION
	LOCATION	EMPLOYMENT OPPORTUNITIES, COMMERCIAL OPPORTUNITIES INCOME GENERATION

Housing involves social welfare and uprise in the social & economic status.

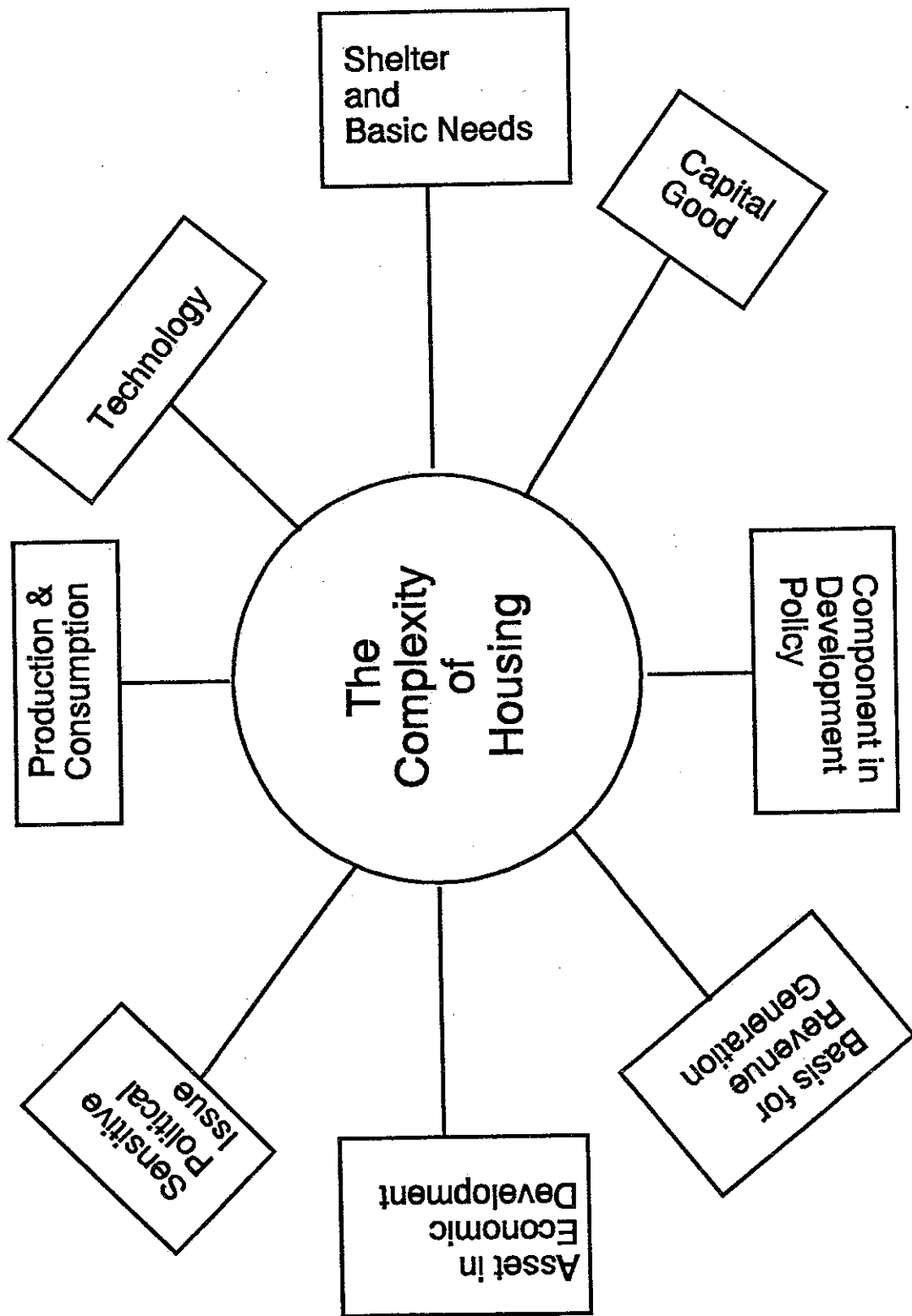

2. THE IMPORTANCE OF HOUSING: tracing back its history.

In order to see where we stand at the moment, let's make a quick historical review in order to see when and how housing became an issue for researchers, policy makers, planners, politicians and so forth.

Housing became an important issue when west European countries started to industrialize and to urbanize themselves in the second half of the last century. It is interesting to note that some of the solutions put forward during this period were going to be transplanted to many developing countries decades later.

Cities were booming and migration from rural areas turned the living conditions in the cities very bad. Existing buildings were suddenly transformed in overcrowded slums subject to health hazards, the appearance of Tuberculosis, etc. Slum clearances and sanitary campaigns accompanied by vaccination programmes were focused on the terrible living condition found in many urban centres of that time e.g. London, Paris, Frankfurt, Rotterdam, just to mention some. In this period, more precisely in 1872, a very important publication appears called "The housing Question", written by Frederick Engels. Based on the economic theories formulated by Karl Marx, he makes a clear linkage between the housing question and the reproduction of the labour force.

Some industrialists realized that indeed to improve his production and to keep high standards in the production output, it was important that his labour force could live in good accommodations. The issue of productivity of the labour force was linked with better housing conditions. Better housing More profit, for some, that was the slogan.

The emergence of the "working class villages" in England, Germany, Austria and in the Netherlands as well is related to that. These were settlement or housing schemes built by some industries or companies to accommodate their employees. The houses were mostly rented occupied, with the rents already discounted in the salary slip and housing occupation fully depended on his permanence in the company.

This was transferred to Latin American countries that were industrializing during the first half of this century. It earmarks the first "momentum" of transfer of knowledge and experience, or models if you like. That was the moment when the parallel between urban policy practices in Europe and USA and those undertaken in developing countries started to become visible.

The second "momentum" came when the garden cities movement and the CIAM, International Congresses of Modern Architecture became the forum of discussion about the future of the industrial cities. The new dogma was to stratify the cities according to its most important functions: working, living, leisure and circulation. Housing should be separated from working places through safety green belts and both functions should be articulated through efficient circulation axis. We were now living the machine age and the rise of the automobile. The postwar period showed a number of examples during the reconstruction of Europe. Some important publications

of this period was the "Garden Cities of Tomorrow" and a series of manifestos coming from the CIAM movement and that was later synthesised by Le Corbusier.

The British new towns movements and a series of plans of satellite cities to alleviate the pressure over the housing stock in London. In Rotterdam, for example, new southern neighbourhoods like Pendrecht, Zuidwijk were constructed. It is interesting to note that English industrialists were pressing the government to launch housing programmes in order to cut down industrial production and labour reproduction costs.

3. HOUSING AND DEVELOPMENT POLICIES IN LDCs

In 1990, we completed the third UN development decade with more poverty than ever before, more illiteracy and many of the development goals and predicted growth unachieved.

It is not necessary to go into statistics to show you the total percentage of the world population that is leaving under poverty line and whose housing conditions are beyond human standards.

3.1 MODERNIZATION AND INDUSTRIALIZATION (1930s to 1970s)

During the pre World War II period, Latin American countries started to launch modernization programmes which were thought to create conditions for changing an agrarian society to an urban industrial society. Import substitution policies and transfer of technology from the Industrialized World was the trademark of this model.

What housing is concerned, a major quantitative approach based on conventional housing programmes and the total eradication of slums (tenement housing) and squatter settlements. It was the policy of the bulldozer. In some cases, housing was more a police problem rather than a policy issue. Throughout the developing world, we registered scenes of brutal slum clearance actions, tackling the symptoms of the problem and leaving untouched its main causes.

Housing was seen as the motor of development and employment generation, stimulating the development of domestic construction sector, in some cases with relevant participation in the growth of the GNP. National housing policies were formulated, state bureaucracies were created (Housing corporations, Housing finance systems, housing banks, etc.). The most representative case of this strategy is Brazil with its BNH, and impressive economic growth during the 70s.

Self-help housing appeared in the scenario. Firstly implemented during the great depression of the 30s in the USA and later introduced in Puerto Rico by the National American Housing and House Finance Authority. Those were more isolated experiments with a pilot and demonstrations status.

3.2 BASIC NEEDS & REDISTRIBUTION WITH GROWTH (1970s-1980s)

There is a critique in the former development model, basically because the growth of GNP reached by many countries was not sufficient to eliminate poverty. The capital surplus was mostly accumulated by a small elite of society. There is now a focus on poverty, unemployment and inequality, a stimulus to private investments. There is attention to the poor's needs.

Informal housing systems was seen as a resourceful provider of housing for a vast majority of the urban poor. Research findings were bringing evidences of the potential economic function of housing and its importance in social and economic development.

What housing is concerned, there is a rise in self-helping housing, advocated by international agencies. Squatter upgrading and sites & services projects became key elements in urban development policies. There is an increase in the World Bank participation in poverty oriented projects.

By the end of the 80s, it was possible to make an evaluation of the results achieved with the involvement of the Bank.

EVALUATION AND SOME IMPORTANT INDICATORS

- a. Some estimates reveals that only 9 million people has been reached by sites & services projects in LDC (Williams, 1984).
- b. The lending of the Bank was concentrated in semi-peripheral countries like Brazil, Mexico, Indonesia.
- c. The poor did not get access to the sites & services and were expelled from upgrading project by economically stronger groups.
- d. There is a strong rationality in project design which lead to the reduction of technical and social standards (minimal services, minimal norms, high densities, smaller plots, etc.) in order to make products more accessible.
- e. The idea of affordability was introduced with the principles of full cost recovery, based on a fixed proportion of income, but it did not pay much attention to maintenance problems and the capacity of the poor to cope with further improvements and complementation of the minimum package.
- f. Self-help housing was stimulated and implied the condition to be employed in order to become eligible for projects. But this self-help was artificial because the beneficiary preferred to contract informal sector labour at a lower rates than the his own in case he would have to invest his hour of labour on his house.

The 1990s started with a four important indicators after three development decades:

1. There is a clear and unresolved debt crisis.
2. There is a low rate of development, with exception for China and some southeast Asian countries.
3. The key word is urban poverty alleviation, with poverty reaching figures never seen before.
4. There is a chronicle inflation.
5. SAP is an attempt to put order in the institutional and financial situation of the countries.

EFFECTS ON THE HOUSING SECTOR

There is an increase in the costs of housing, land and infrastructure.

There is an increase in building materials, very often caused by the import of fuels.

There is a constrain and shortage in housing supply.

There is a rapid decrease in subsidies for housing which makes access more difficult.

There is more obstacles to have access to housing mortgages.

Many important housing finance institutions in LDCs have collapsed (BNH, INFAVIT).

There is an increase in tax related to housing and infrastructure.

The difficulties in access to housing finance is creating a competition for housing in informal settlements (the appearance of middle income groups in this market).

There is a rapid increase in land prices.

Renting is increasing and many cities are experimenting the phenomenon of overcrowding.

Second generation urbanization migrants are facing much more difficulties to move from rental to home ownership, with the result of incredible rates of housing occupancy (overcrowding).

The government is increasing the control over illegal settlements.

SOME TRENDS

There is tendency to replace capital by labour and a reorientation of demands towards labour intensive processes.

This emphasis to labour intensive processes is bound to produce certain patterns of underdeveloped technology, simply to guarantee certain levels of employment.

There has been no redistribution of existing incomes but of income increments derived from the phenomenon of growth.

REPLICABILITY IS THE KEY ISSUE



FROM
Project Lending
TO
Policy Lending

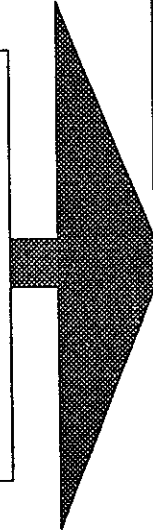

INSTITUTIONAL REFORM
and
DECENTRALIZATION

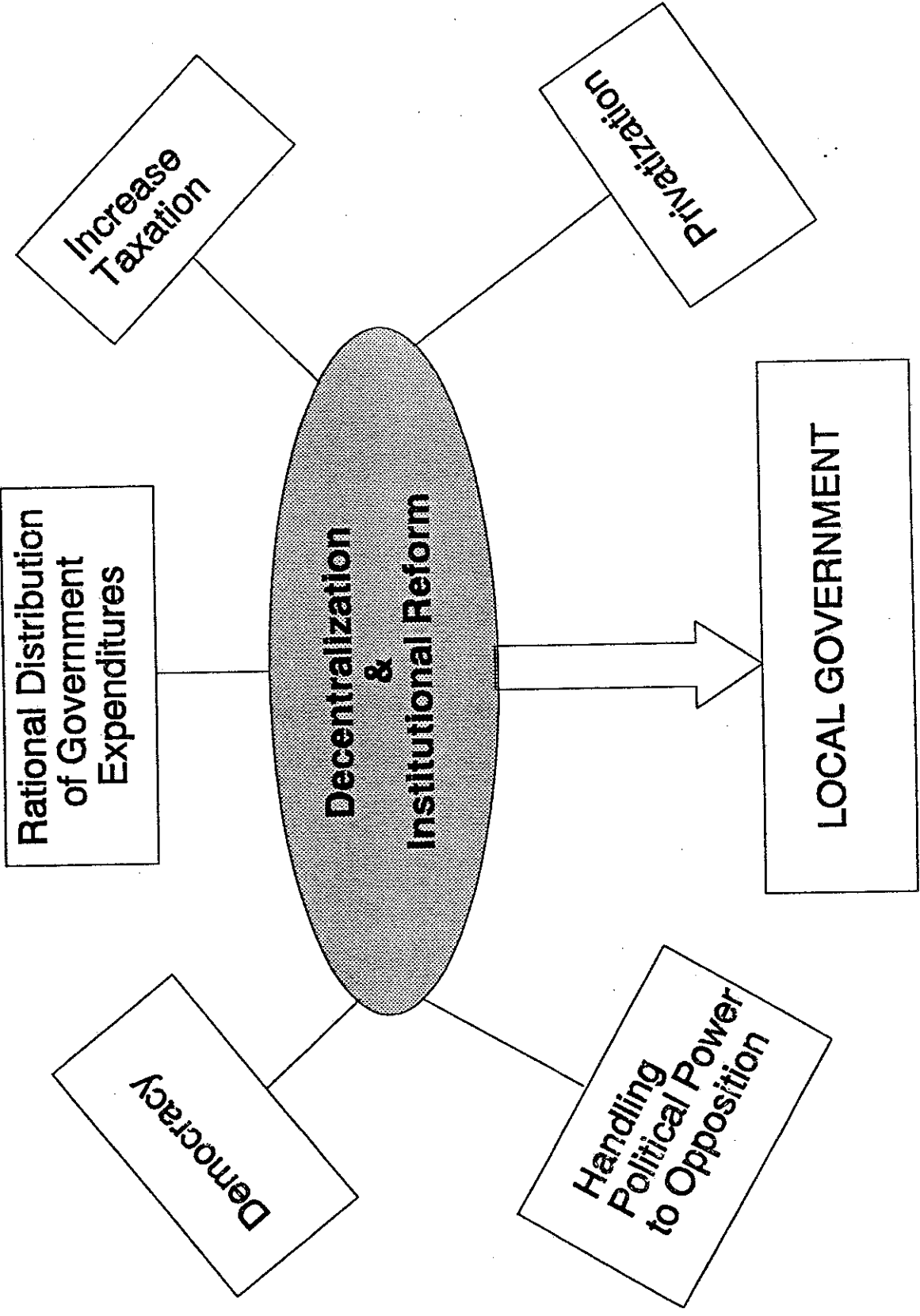

The international agendas are advocating a shift from PROJECT/PRODUCTS to PROCESSES/CITY WIDE LEVEL, covering the whole population.

The linkage with poverty groups is less defined and explicit in terms of lending and financial resource allocation.

Social urban movements and CBOs are forced to organize themselves in order to guarantee the allocation of financial resources in their localities or to shift political decision and policy measures towards their interests.

There is an obvious increase in the tax base and full effort to revenue collection and full cost recovery.

Replicability becomes a key issue. From affordability, cost-recovery and replicability, a line is drawn by bank and donors which shifts from project lending to policy lending. As a prerequisite, it must occur an institutional reform and decentralization.

Decentralization implies:

- DEMOCRACY
- RATIONAL DISTRIBUTION OF GOVERNMENT EXPENDITURES.
- INCREASE IN TAXATION
- HANDLING POLITICAL POWER TO OPPOSITION
- PRIVATIZATION

Where are we going to ?

electricity		urb/env. management
employment generation	housing	solid waste
water	disappears	informal sector
incremental land development		sewerage

We are going to HOUSING WITHOUT HOUSES.

It is difficult to see the shift from one idea/model to the other. There are some peculiarities of each country in the three continents LA, Asia, Africa and very often, there is still vestiges of the older model while other views are carried out, even within the same country.

RENTED OCCUPATION	HOME OWNERSHIP	?
HOUSING AS A PRODUCT	HOUSING AS PROCESS	H O U S I N G WITHOUT HOUSES.
GOVERNMENT AS PROVIDER	GOV. AS INITIATOR	G O V . A S ENABLER OR FACILITATOR
HOUSING AS ASSET IN NATIONAL DEVELOPMENT	HOUSING AS A BASIC NEED	HOUSING AS A LOCAL PROBLEM

The problem is becoming a management/institutional issue and not a political problem.

The relationships between housing and macro economic policies and SAP are becoming more evident.

Everything is argued as government failures and never as market failures. The first one is known already to be far from being perfect but about the latter, nothing much is done to respond this question. We are living on a hang over from the neo-liberal revolution and it will take a little while for us to wake up and realize that we should look for another way.

Global Strategy for Shelter to the Year 2000-GSS (UN general assembly in 1988)
The establishment of the idea of enablement: governments should strive to implement policies that will facilitate, energize and support the activities of the private sector, both formal and informal, in housing development.

In October 1990, the HOUSING INDICATOR PROGRAM (UNCHS and World Bank). The programme conducted an extensive survey covering 52 countries and an intensive survey in selected countries (Hungary and the Philippines). Data from household surveys conducted by the World Bank in the past and additional data from UN sources were also included.

A series of regional meetings were organized: hosted by the Government Housing Bank of Thailand (Nov/91), hosted by UNCHS in Nairobi (Jan/92), hosted by Ecuador Housing Bank (Feb/92). The program is financed by UNCHS, World Bank, Finnish International Development Agency, USAID, with a total of US\$1.054 million.

1. A comprehensive conceptual and analytical framework for monitoring the performance of the housing sector.
2. Formulate practical tools for measuring the performance of the housing sector.
3. Provide empirical information related to policy making through the result of the Extensive Survey.
4. New institutional frameworks that will be more appropriate for managing the housing sector.
5. Stimulate research and disseminate findings.

Housing is increasingly viewed as a commodity with an exchange value, even in centrally or formerly centrally planned economies.

Housing policy must be sufficiently differentiated to deal with particular submarkets. Prices and affordability by different income groups are determined in the market by demand and supply.

Housing demand: determined by demographic conditions, rate of urbanization, rate of new household formation, macro-economic conditions affecting household incomes.

Housing supply: affected by availability of resource input like land, infrastructure, construction materials, organization of the construction industry, availability of skilled and productive labour and dependence on imports.

Supply & Demand: affected by regulatory, institutional and policy environment.

To develop a normative view of the housing sector, one must look at how the sector performs from different perspectives:

1. Housing consumers
2. Housing producers
3. Housing finance institutions
4. Local governments
5. Central governments

GENERAL RULES TO UNDERSTAND THE PERFORMANCE OF THE HOUSING SECTOR

When housing inputs falls behind the demand, access to home ownership declines and more and more families are forced into rented accomodation.

If the restrictions in housing delivery continues to grow, conditions in the rental market deteriorates (rent increases, overcrowding), housing quality falls, residential densities rise, property-ownership becomes more concentrated and speculation is widespread.

*from: The housing indicator program. Angel, Lays, Stephens
Netherlands Journal of Housing and the Built Environment, Vol. 8
1993 no. 1.*

1. **Housing consumers:** Everyone is housed, with a separate unit for every household. Housing does not take up an undue portion of household income. House prices are not subject to undue variability. Living space is adequate. Structures are safe and provide adequate protection from the elements, fire, and natural disasters. Services and amenities are available and reliable. Location provides good access to employment. Tenure is secure and protected by due process of law. Households may freely choose among different housing options and tenures (owning vs. renting). Finance is available to smooth expenses over time and allow households to save and invest. Adequate information is available to ensure efficient choice.

2. **Housing producers:** Adequate supply of residential land is available at reasonable prices. Infrastructure networks are adequate and do not hold back residential development. Building materials and equipment and sufficient skilled labor are available at reasonable prices. Entry of new firms into the residential construction sector is not impeded. The residential construction sector is not discriminated against by special tariffs or controls. Adequate financing is available. Housing production and investment can respond to changes in demand without undue delay. Contracts are enforceable. Regulations concerning land development, land use, building, land tenure, taxation, or special programs are well defined and predictable, and government application of these is efficient, timely, and uniform. Adequate information exists to enable producers to forecast housing demand with reasonable certainty. Rates of return on all types of housing investment, including rental housing, are sufficient to maintain incentives for investment.

3. **Housing finance institutions:** Housing finance institutions are permitted to compete for deposits on equal terms with other financial institutions; the role of directed credit is minimized. Housing finance institutions are not forced to compete unfairly with subsidized finance. Lending is at positive real interest rates with a sufficient margin to maintain institutional health. There are sufficient deposits of an appropriate term structure for long-term mortgage lending. Mortgage lending instruments are permitted which are in demand by households and provide adequate protection for the institution. Systems of property rights, tenure security, and foreclosure are such that the financial interests of lenders can be protected. Appropriate institutions exist that protect financial institutions against undue mortgage lending risk.

4. **Local governments:** Housing and associated infrastructures are of adequate quality to maintain public health, safety standards, and environmental quality. Infrastructure networks and services are extended quickly to all communities. The location of new communities is close to existing main networks. Land use is productive and efficient. Sufficient land can be obtained for laying infrastructure networks and providing local amenities and public services. Housing provides a major source of municipal revenues for building and maintaining infrastructure services and neighborhood amenities.

5. **Central governments:** Adequate, affordable housing is available to all. Targeted subsidies are available to help households that cannot afford minimum housing. Housing-sector policy is integrated into national social and economic planning. Housing-sector performance is monitored regularly. The housing sector contributes toward broad social and economic objectives: (1) alleviating poverty; (2) controlling inflation; (3) generating household savings and mobilizing household productive resources; (4) generating employment and income growth; (5) enabling social and spatial mobility; (6) increasing productivity; (7) generating investment growth; (8) accumulating national wealth; (9) reducing the balance of payments deficit; (10) reducing the government budget deficit; (11) developing the financial system; and (12) protecting the environment.

While the above list may be incomplete, it does provide a broad normative view of a well-functioning housing sector from the perspectives of its key actors. Needless to say, these perspectives are not necessarily mutually consistent. What may benefit one may damage another. Rent control, for example, may benefit families already housed but may prevent further investment in rental housing and discriminate against new residents. Reducing house prices may benefit housing seekers but reduce the asset value of those owning houses. Increasing land supply may be at the expense of environmental amenities. Stronger foreclosure laws may increase mortgage financing for all at the expense of evictions for some. Resolving these incompatible interests is one of the most fundamental tasks of an effective housing policy.

The Housing Indicators Program has taken the conceptual framework and the norms for a well-functioning housing sector as the basic framework for generating a comprehensive set of indicators for measuring housing-sector performance. Indicators were designed to cover housing supply, including the cost and availability of key inputs such as land, infrastructure, building materials, industrial organization, and the regulatory environment. Indicators of housing demand cover demographic variables, finance, and subsidies. And indicators of housing outcomes include prices, quantities, and the qualitative features of the housing stock. All key norms for a well-functioning housing sector were translated, as far as possible, into quantitative indicators. These were then tested and collected in the Extensive Survey, which is briefly described below.

3. The Extensive Survey of 52 countries

The Housing Indicators Program is involved in the collection of data from four major sources:

1. The *Extensive Survey* of Housing Indicators;
2. The *Intensive Survey* of housing indicators in selected countries (Hungary and the Philippines);
3. *Household surveys* in ten countries conducted by the World Bank during the past decade; and

TYPE OF INDICATOR	KEY HOUSING INDICATOR	MEANING	LOW	MEDIAN	HIGH	INTERPRETATIONS
PRICE INDICATORS	1. The house-price-to- income ratio	Ratio of the median free market price of a dwelling unit and the median annual household income.	0.9	5.0	14.8	It measures housing affordability. If high, system is restricted. If low, insecurity of tenure.
	2. The rent-price-to-income ratio	Ratio of the median annual rent of dwelling unit and the median annual household income of renters	0.03	0.18	0.38	Also a key to check housing affordability. If low, rent control measures. If high, rental housing failing to meet demand.
QUANTITY INDICATORS	3. Housing production	Total number of housing units (formal & informal) produced last year per 1000 population.	2.0	6.8	14	Measures the importance of housing sector to broader economy. Ability of the delivery systems.
	4. Housing investment	Total investment in housing (formal & informal), as percentage of gross city product.	0.009	0.04	0.088	Reflects quantities produced and prices. A given value may reflect either high unit costs and low volumes or low costs and high volumes of production.
QUALITY INDICATORS	5. Floor Area per person	The median usable living space per person (m ²) last year.	4	33	69	Low value is sign of overcrowding.
	6. Permanent structures	The percentage of housing units located in structures built of permanent materials.	0.43	0.90	1.0	Measures quality of housing, durability. Primitive measure of housing adequacy.
	7. Unauthorized Housing	Percentage of the total housing stock that is not compliance with current regulations.	0.0	0.24	0.78	Unauthorized housing decreases sharply with economic development.

INTRODUCTION TO HOUSING (ICHPB 64): Draft and lecture notes **Claudio Acioly Jr.**

DEMAND-SIDE INDICATORS	8. The housing credit portfolio	0.01	0.18	0.44	Measures the relative size of housing finance sector and its ability to provide households with \$ to purchase housing.
SUPPLY-SIDE INDICATORS	9. The land development multiplier	1.1	5.2	16.6	Measures premium for providing infrastructure and converting raw land to residential use on the urban fringe.
	10. Infrastructure expenditures per capita	0.98	318	2,201	Is an indirect measure of the supply of infrastructure for residential development. If low, land-supply bottlenecks and higher prices of land and housing.
		<p>The ratio of total mortgage loans to all outstanding loans in both commercial and governmental institutions.</p> <p>Average ratio between the median land price of a developed plot at the urban fringe in typical subdivision and the median price of raw, undeveloped land in an area currently being developed.</p> <p>The ratio of total expenditures (operations, maintenance and \$), by all levels of government on infrastructure services (roads, sewerage, drainage, water supply, electricity, garbage collection) during the current year to the urban population). Median is \$73. Median for low income countries is \$15. Median for high income countries is \$814 or 54 times as high. It is equivalent to the factor that per capita incomes differ across income groups.</p>			

Source: Data extracted from "The Housing Indicator Program. A report on progress and plans for the future". By S. Angel, S.K. Mayo and W.L. Stephen, Jr. in Netherlands Journal of Housing and the Built Environment, Vol. 8 (1993), no. 1. The survey covered 52 countries divided in 5 different income groups and 6 regions: (1)Africa, (2)South Asia, (3)East Asia, (4)EMENA (Europe, Middle East and North Africa), (5)LAC (Latin America and Caribbean) and (6)Industrialized countries.

- 1 Planning and planners should be brought into close contact with the people especially with respect to the expressed aspirations of the poor and the potential for self-determination (p. 22).
- 2 Communities should be involved in the planning, implementation and management of neighbourhood schemes (p. 32).
- 3 Standards for shelter, infrastructure and services should be based on the felt needs and priorities of the population (p. 41).
- 4 Legislative, institutional and financial measures should be reoriented to facilitate people's involvement in meeting their own needs for social services (p. 55).
- 5 Public participation is a right of everyone and special efforts should be made to expand and strengthen the role of community organizations, workers' organizations, tenants' and neighbourhood organizations (p. 76).

EXTRACT FROM THE VANCOUVER RESOLUTION
UN CONFERENCE ON HUMAN SETTLEMENTS (1976)

IN R.J. SKINNER and M.J. RODELL (1983), "PEOPLE POVERTY & SHELTER",
page 13.

Upgrading

R. J. MARTIN

3.1 Introduction

At the risk of being simplistic, this chapter starts with a brief statement of the advantages of upgrading, as found in the majority of situations.

- 1 It preserves existing economic systems and opportunities for those most in need, the urban poor.
- 2 It preserves a low-cost housing system, usually at advantageous locations, thus enabling the inhabitants to retain the maximum disposable income.
- 3 It preserves a community which has many internal linkages to safeguard the interests of the individual family and the group.
- 4 The alternative to upgrading is relocation in one form or another: this is socially disruptive and by usually being to a much less favourable location, results in higher transport costs and less access to informal employment opportunities.

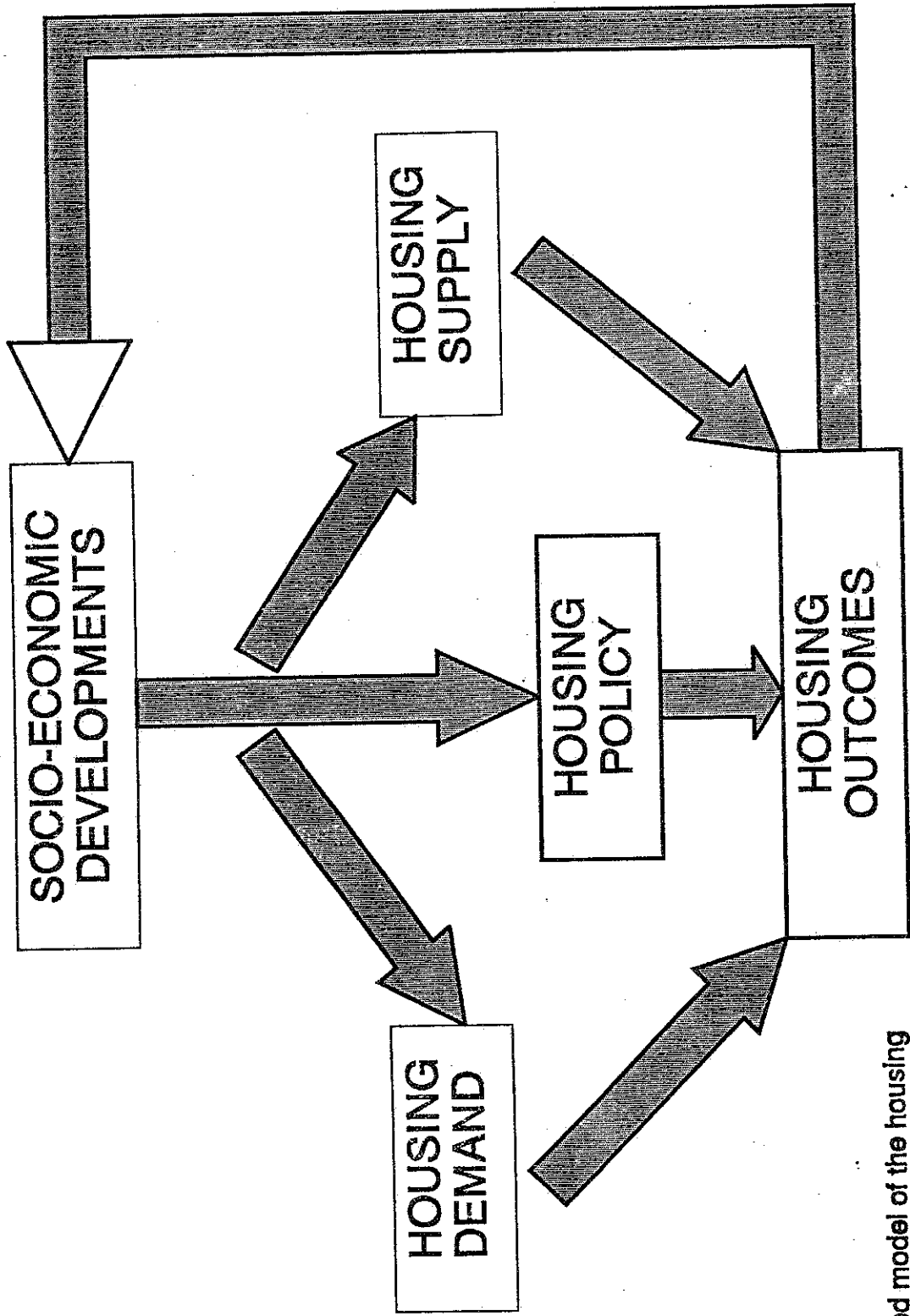

Amended model of the housing sector, by H. Priemus, TUDeift.

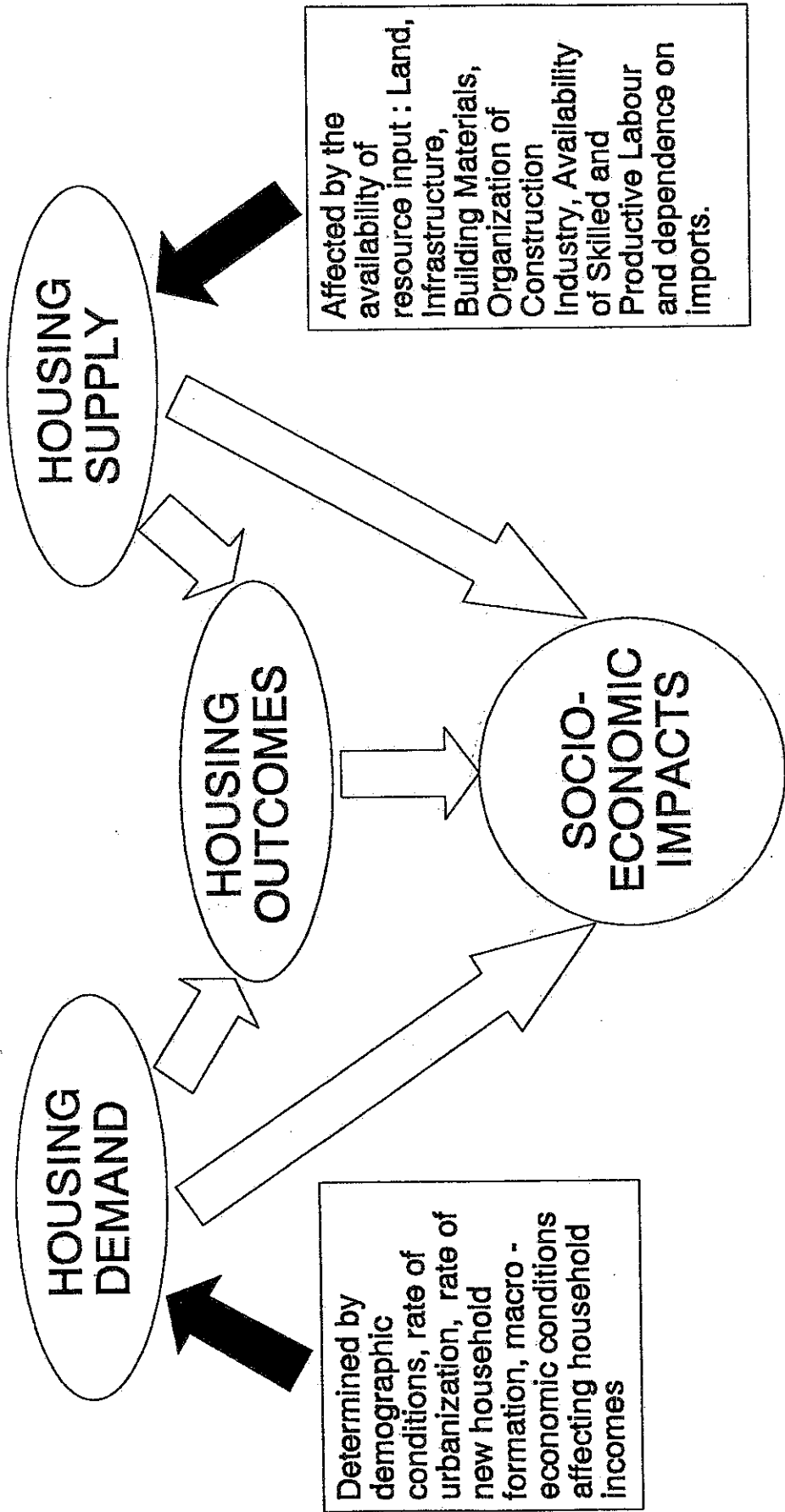

To develop a normative view of the Housing Sector, one must look at how the sector performs from several perspectives. The five most important perspectives are those of Housing Consumers, Housing Producers, Housing Finance Institutions, Local Governments, and Central Governments.

Figure based on the Housing Indicators Programme, World Bank.